



2.10 Casquillos de fijación



2. Piñones, Discos, Tapers y casquillos de fijación



C&S 13 / SERIE KL AA

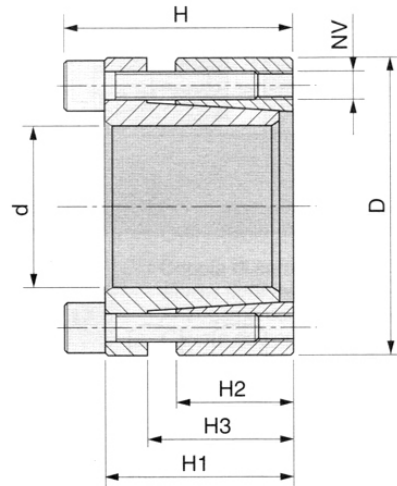

Dimensiones

Nuestro código	Dimensiones						Fuerza de bloqueo			Desbloqueo		Par			
	d	D	H3	H1	H	H2	NV	Tv (Nm)	Tornillos	NV	Tornillos	Mt (Nm)	Pa (N/mm ²)	Ta (KN)	Pm (N/mm ²)
KLAA019	19	47	22	28	34	17	M6	14	5	M6	3	355	280	31	120
KLAA020	20	47	22	28	34	17	M6	14	5	M6	3	360	280	33	120
KLAA022	22	47	22	28	34	17	M6	14	5	M6	3	400	268	33	123
KLAA024	24	50	22	28	34	17	M6	14	6	M6	3	440	243	36	120
KLAA025	25	50	22	28	34	17	M6	14	6	M6	3	560	280	36	138
KLAA028	28	55	22	28	34	17	M6	14	6	M6	3	625	250	36	128
KLAA030	30	55	22	28	34	17	M6	14	6	M6	3	650	235	36	128
KLAA032	32	60	22	28	34	17	M6	14	8	M6	4	950	290	50	150
KLAA035	35	60	22	28	34	17	M6	14	8	M6	4	1050	268	50	150
KLAA038	38	65	22	28	34	17	M6	14	8	M6	4	1140	252	50	146
KLAA040	40	65	22	28	34	17	M6	14	8	M6	4	1200	232	50	146
KLAA045	45	75	25	33	41	20	M8	35	7	M8	3	2180	285	70	168
KLAA050	50	80	25	33	41	20	M8	35	7	M8	3	2430	258	85	158
KLAA055	55	85	25	33	41	20	M8	35	8	M8	4	3050	268	85	173
KLAA060	60	90	25	33	41	20	M8	35	8	M8	4	3350	243	85	163
KLAA065	65	95	25	33	41	20	M8	35	9	M8	3	4080	253	85	173
KLAA070	70	110	30	40	50	24	M10	70	8	M10	4	6280	278	119	178
KLAA075	75	115	30	40	50	24	M10	70	8	M10	4	6680	258	119	168
KLAA080	80	120	30	40	50	24	M10	70	8	M10	4	7130	248	119	168
KLAA085	85	125	30	40	50	24	M10	70	9	M10	3	8750	258	132	178
KLAA090	90	130	30	40	50	24	M10	70	9	M10	3	9080	248	132	168
KLAA095	95	135	30	40	50	24	M10	70	10	M10	4	10580	258	132	178
KLAA100	100	145	32	44	56	26	M12	125	8	M12	4	13380	268	170	188
KLAA110	110	155	32	44	56	26	M12	125	8	M12	4	14580	238	170	178
KLAA120	120	165	32	44	56	26	M12	125	9	M12	4	17880	248	200	178
KLAA130	130	180	40	52	64	34	M12	190	12	M12	6	25950	238	270	168
KLAA140	140	190	40	54	68	34	M14	190	9	M14	4	26950	208	270	148
KLAA150	150	200	40	54	68	34	M14	190	10	M14	5	32950	228	320	168



2. Piñones, Discos, Tapers y casquillos de fijación

C&S 16 / SERIE KL AB

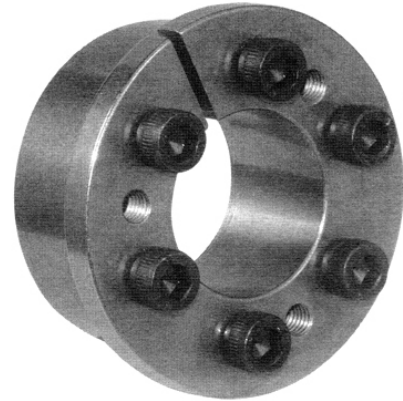
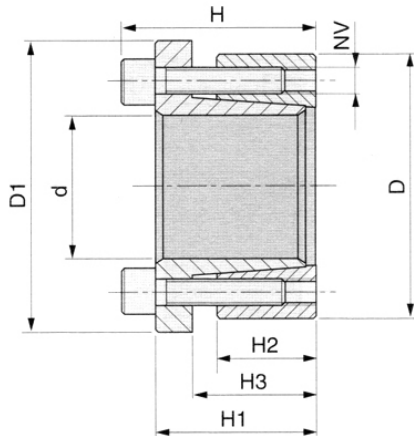

Dimensiones

Nuestro código	Dimensiones							Fuerza de bloqueo			Desbloqueo		Par			
	d	D	D1	H	H1	H2	H3	NV	Tv (Nm)	Tornillos	NV	Tornillos	Mt (Nm)	Pa (N/mm ²)	Ta (KN)	Pm (N/mm ²)
KLAB019	19	47	56	34	28	17	22	M6	17	5	M6	3	274	215	28	93
KLAB020	20	47	56	34	28	17	22	M6	17	5	M6	3	284	215	32	93
KLAB022	22	47	56	34	28	17	22	M6	17	5	M6	3	314	196	32	93
KLAB024	24	50	59	34	28	17	22	M6	17	6	M6	3	401	215	32	107
KLAB025	25	50	59	34	28	17	22	M6	17	6	M6	3	441	210	34	107
KLAB028	28	55	64	34	28	17	22	M6	17	6	M6	3	490	196	34	98
KLAB030	30	55	64	34	28	17	22	M6	17	6	M6	3	529	186	34	98
KLAB032	32	60	69	34	28	17	22	M6	17	8	M6	4	755	210	46	112
KLAB035	35	60	69	34	28	17	22	M6	17	8	M6	4	824	186	46	107
KLAB038	38	65	74	34	28	17	22	M6	17	8	M6	4	892	191	46	112
KLAB040	40	65	74	34	28	17	22	M6	17	8	M6	4	941	186	46	102
KLAB045	45	75	84	41	33	20	25	M8	41	7	M8	3	1716	225	64	132
KLAB050	50	80	84	41	33	20	25	M8	41	7	M8	3	1893	205	85	127
KLAB055	55	85	94	41	33	20	25	M8	41	8	M8	4	2403	210	85	132
KLAB060	60	90	99	41	33	20	25	M8	41	8	M8	4	2648	186	85	122
KLAB065	65	95	104	41	33	20	25	M8	41	9	M8	3	3188	196	85	132
KLAB070	70	110	119	50	40	24	30	M10	83	8	M10	4	4905	215	119	137
KLAB075	75	115	124	50	40	24	30	M10	83	8	M10	4	5150	195	119	127
KLAB080	80	120	129	50	40	24	30	M10	83	8	M10	4	5490	185	119	122
KLAB085	85	125	134	50	40	24	30	M10	83	9	M10	3	6620	195	132	132
KLAB090	90	130	139	50	40	24	30	M10	83	9	M10	3	6960	185	132	127
KLAB095	95	135	144	50	40	24	30	M10	83	10	M10	4	8190	195	132	137
KLAB100	100	145	154	56	44	26	32	M12	145	8	M12	4	10100	205	170	145
KLAB110	110	155	164	56	44	26	32	M12	145	8	M12	4	11030	190	170	135
KLAB120	120	165	174	56	44	26	32	M12	145	9	M12	4	13600	205	200	142
KLAB130	130	180	189	64	52	34	40	M12	145	12	M12	6	19000	186	270	137
KLAB140	140	190	199	68	54	34	40	M14	230	9	M14	4	21800	177	270	127
KLAB150	150	200	209	68	54	34	40	M14	230	10	M14	5	25600	185	320	137

2. Piñones, Discos, Tapers y casquillos de fijación



C&S 15 / SERIE KL BB

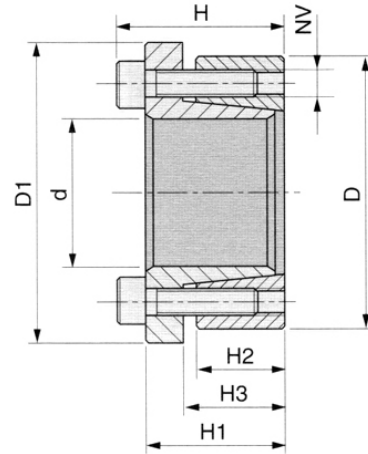

Dimensiones

Nuestro código	Dimensiones							Fuerza de bloqueo			Desbloqueo		Par			
	d	D	D1	H	H1	H2	H3	NV	Tv (Nm)	Tornillos	NV	N° Viti	Mt (Nm)	Pa (N/mm ²)	Ta (KN)	Pm (N/mm ²)
KLBB114	14	55	63	39	31	17	22	M8	42	4	M8	2	290	460	40	110
KLBB116	16	55	63	39	31	17	22	M8	42	4	M8	2	330	400	40	110
KLBB118	18	55	63	39	31	17	22	M8	42	4	M8	2	370	360	40	110
KLBB119	19	55	63	39	31	17	22	M8	42	4	M8	2	390	340	40	110
KLBB120	20	55	63	39	31	17	22	M8	42	4	M8	2	410	320	40	110
KLBB122	22	55	63	39	31	17	22	M8	42	4	M8	2	450	290	40	110
KLBB124	24	55	63	39	31	17	22	M8	42	4	M8	2	490	270	40	110
KLBB125	25	55	63	39	31	17	22	M8	42	4	M8	2	510	260	40	110
KLBB128	28	55	63	39	31	17	22	M8	42	4	M8	2	570	230	40	110
KLBB130	30	55	63	39	31	17	22	M8	42	4	M8	2	610	220	40	110
KLBB224	24	65	72	39	31	17	22	M8	42	5	M8	3	610	330	50	120
KLBB225	25	65	72	39	31	17	22	M8	42	5	M8	3	640	320	50	120
KLBB228	28	65	72	39	31	17	22	M8	42	5	M8	3	710	290	50	120
KLBB230	30	65	72	39	31	17	22	M8	42	5	M8	3	770	270	50	120
KLBB232	32	65	72	39	31	17	22	M8	42	5	M8	3	820	250	50	120
KLBB235	35	65	72	39	31	17	22	M8	42	5	M8	3	890	230	50	120
KLBB238	38	65	72	39	31	17	22	M8	42	5	M8	3	970	210	50	120
KLBB240	40	65	72	39	31	17	22	M8	42	5	M8	3	1020	200	50	120
KLBB330	30	80	87	41	33	20	25	M8	42	7	M8	3	1070	320	70	110
KLBB332	32	80	87	41	33	20	25	M8	42	7	M8	3	1140	300	70	110
KLBB335	35	80	87	41	33	20	25	M8	42	7	M8	3	1250	270	60	110
KLBB338	38	80	87	41	33	20	25	M8	42	7	M8	3	1350	250	60	110
KLBB340	40	80	87	41	33	20	25	M8	42	7	M8	3	1420	240	70	110
KLBB342	42	80	87	41	33	20	25	M8	42	7	M8	3	1500	230	70	110
KLBB345	45	80	87	41	33	20	25	M8	42	7	M8	3	1600	210	60	110
KLBB348	48	80	87	41	33	20	25	M8	42	7	M8	3	1710	200	70	110
KLBB350	50	80	87	41	33	20	25	M8	42	7	M8	3	1780	190	60	110



2. Piñones, Discos, Tapers y casquillos de fijación

C&S 80 / SERIE KL CC

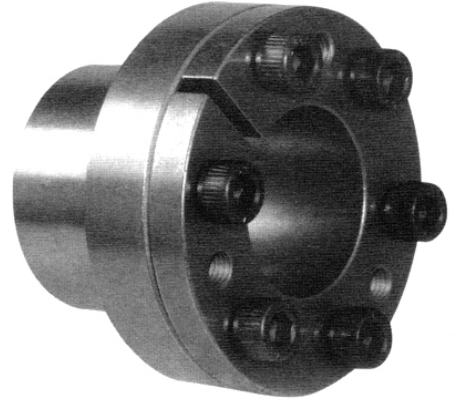
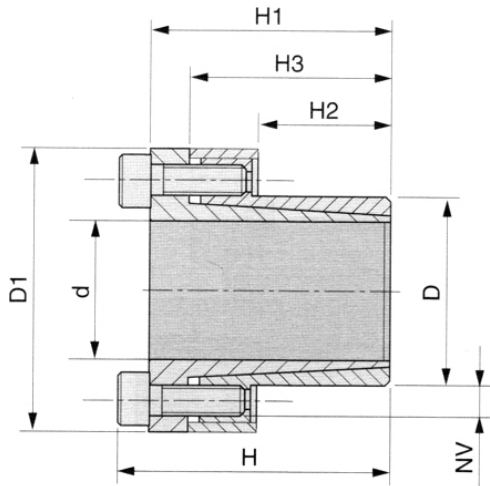

Dimensiones

Nuestro código	Dimensiones							Fuerza de bloqueo			Desbloqueo		Par			
	d	D	D1	H	H1	H2	H3	NV	Tv (Nm)	Tornillos	NV	Tornillos	Mt (Nm)	Pa (N/mm ²)	Ta (KN)	Pm (N/mm ²)
KLCC008	8	15	32	28	24	12	21	M4	5,2	3	M4	2	30	190	7,19	105
KLCC009	9	16	32	31	27	14	23	M4	5,2	3	M4	3	32	150	7,19	92
KLCC010	10	16	32	31	27	14	23	M4	5,2	3	M4	3	40	140	9	90
KLCC011	11	18	34	31	27	14	23	M4	5,2	4	M4	3	50	175	9	107
KLCC012	12	18	34	31	27	14	23	M4	5,2	4	M4	3	55	161	9	107
KLCC014	14	23	39	31	27	14	23	M4	5,2	4	M4	3	64	137	9	84
KLCC015	15	24	45	42	36	16	29	M6	17	4	M6	2	99	162	13	101
KLCC016	16	24	45	42	36	16	29	M6	17	4	M6	2	105	152	13	101
KLCC018	18	26	47	44	38	18	31	M6	17	4	M6	3	158	160	18	111
KLCC019	19	27	48	44	38	18	31	M6	17	4	M6	3	167	151	18	107
KLCC020	20	28	49	44	38	18	31	M6	17	4	M6	3	176	144	21	103
KLCC022	22	32	54	51	45	25	38	M6	17	4	M6	3	232	113	21	78
KLCC024	24	34	56	51	45	25	38	M6	17	4	M6	3	253	103	21	73
KLCC025	25	34	56	51	45	25	38	M6	17	4	M6	3	263	99	21	73
KLCC028	28	39	61	51	45	25	38	M6	17	6	M6	3	368	111	31	80
KLCC030	30	41	63	51	45	25	38	M6	17	6	M6	3	474	124	31	91
KLCC032	32	43	65	56	50	30	43	M6	17	6	M6	3	505	97	31	72
KLCC035	35	47	69	56	50	30	43	M6	17	8	M6	4	737	119	42	88
KLCC038	38	50	72	56	50	30	43	M6	17	8	M6	4	800	109	42	83
KLCC040	40	53	75	58	52	32	45	M6	17	8	M6	4	947	109	53	82
KLCC042	42	55	77	58	52	32	45	M8	42	8	M8	4	994	104	78	79
KLCC045	45	59	85	72	64	40	56	M8	42	8	M8	4	1750	127	78	97
KLCC048	48	62	88	72	64	40	56	M8	42	8	M8	4	1867	119	78	92
KLCC050	50	65	92	82	74	50	66	M8	42	10	M8	5	2431	115	97	98
KLCC055	55	71	98	82	74	50	66	M8	42	10	M8	5	2674	104	97	81
KLCC060	60	77	104	82	74	50	66	M8	42	10	M8	5	2917	96	97	74
KLCC065	65	84	111	82	74	50	66	M10	42	10	M10	5	3160	88	97	69
KLCC070	70	90	122	101	91	60	80	M10	84	10	M10	4	4322	87	123	67
KLCC075	75	95	126	101	91	60	80	M10	84	10	M10	4	6171	93	197	74
KLCC080	80	100	131	106	96	65	85	M10	84	12	M10	5	7899	97	237	77
KLCC085	85	106	137	106	96	65	85	M10	84	12	M10	5	8393	91	237	73
KLCC090	90	112	143	106	96	65	85	M10	84	12	M10	6	10367	100	276	51
KLCC095	95	120	153	106	96	65	85	M12	84	14	M12	6	10943	95	276	75
KLCC100	100	125	162	114	102	65	89	M12	145	12	M12	5	14520	114	348	91
KLCC110	110	140	177	119	107	70	94	M12	145	14	M12	5	15972	96	348	75
KLCC120	120	155	195	139	127	90	114	M12	145	18	M12	7	23232	91	465	71
KLCC130	130	165	205	139	127	90	114	M12	145	18	M12	7	25168	84	465	66

2. Piñones, Discos, Tapers y casquillos de fijación



C&S 70 / SERIE KL DA

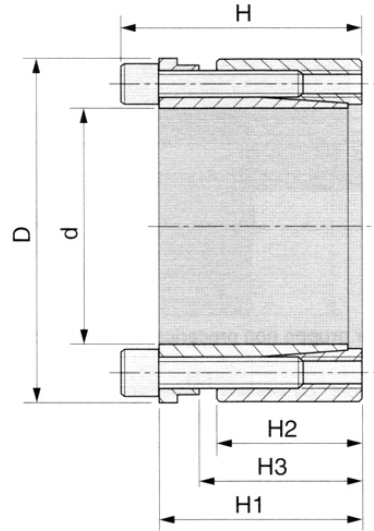
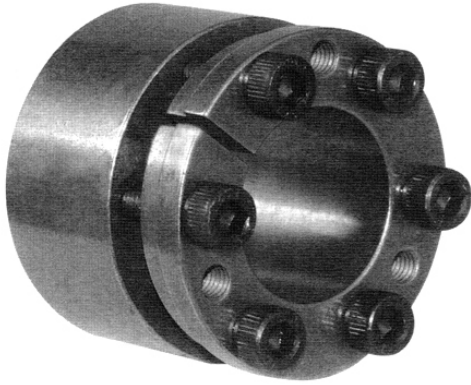

Dimensiones

Nuestro código	Dimensiones						Fuerza de bloqueo			Desbloqueo		Par			
	d	D	H	H1	H2	H3	NV	Tv (Nm)	Tornillos	NV	Tornillos	Mt (Nm)	Pa (N/mm ²)	Ta (kN)	Pm (N/mm ²)
KLDA019	19	47	45	39	26	31	M6	17	4	M6	2	353	228	30,6	98
KLDA020	20	47	45	39	26	31	M6	17	4	M6	2	382	226	33,4	98
KLDA022	22	47	45	39	26	31	M6	17	4	M6	2	431	215	33,4	93
KLDA024	24	50	45	39	26	31	M6	17	6	M6	3	519	215	50,2	102
KLDA025	25	50	45	39	26	31	M6	17	6	M6	3	578	225	50,2	102
KLDA028	28	55	45	39	26	31	M6	17	6	M6	3	686	215	50,2	107
KLDA030	30	55	45	39	26	31	M6	17	6	M6	3	745	196	50,2	117
KLDA032	32	60	45	39	26	31	M6	17	8	M6	4	912	225	66,9	111
KLDA035	35	60	45	39	26	31	M6	17	8	M6	4	1010	196	66,9	116
KLDA038	38	65	45	39	26	31	M6	17	8	M6	4	1216	205	66,9	121
KLDA040	40	65	45	39	26	31	M6	17	8	M6	4	1323	196	66,9	122
KLDA042	42	75	55	47	30	36	M8	41	6	M8	3	2128	232	66,9	137
KLDA045	45	75	55	47	30	36	M8	41	6	M8	3	2304	232	92,1	137
KLDA048	48	80	55	47	30	36	M8	41	6	M8	3	2461	213	110	132
KLDA050	50	80	55	47	30	36	M8	41	6	M8	3	2530	213	122,8	132
KLDA055	55	85	55	47	30	36	M8	41	8	M8	4	3138	218	122,8	142
KLDA060	60	90	55	47	30	36	M8	41	8	M8	4	3314	194	122,8	153
KLDA065	65	95	55	47	30	36	M8	41	8	M8	4	4079	208	122,8	137
KLDA070	70	110	67	57	40	46	M10	83	8	M10	4	6707	220	193,5	140
KLDA075	75	115	72	62	40	46	M10	83	8	M10	4	7354	205	193,5	135
KLDA080	80	120	72	62	40	46	M10	83	8	M10	4	7943	196	193,5	127
KLDA085	85	125	72	62	40	46	M10	83	10	M10	4	9512	205	241,9	142
KLDA090	90	130	72	62	40	46	M10	83	10	M10	4	10100	196	241,9	135
KLDA095	95	135	72	62	40	46	M10	83	10	M10	4	11865	205	241,9	145
KLDA100	100	145	89	77	46	52	M12	145	8	M12	4	15396	211	282,8	145
KLDA110	110	155	89	77	46	52	M12	145	8	M12	4	16867	192	282,8	136
KLDA120	120	165	89	77	46	52	M12	145	10	M12	4	22064	211	353,6	152
KLDA130	130	180	89	77	46	52	M12	145	12	M12	4	23535	192	424,3	137
KLDA140	140	190	90	84	51	59	M14	230	8	M14	4	30210	192	448,5	142
KLDA150	150	200	90	84	51	59	M14	230	10	M14	5	36440	201	489	150



2. Piñones, Discos, Tapers y casquillos de fijación

C&S 71 / SERIE KL DB

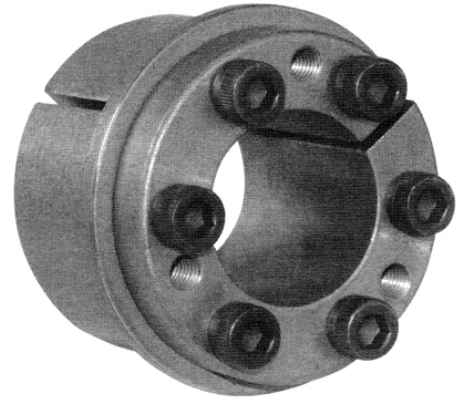
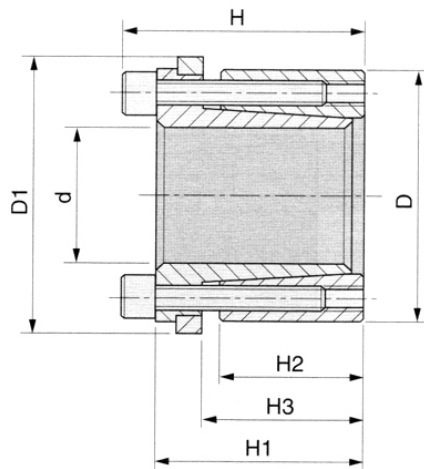

Dimensiones

Nuestro código	Dimensiones							Fuerza de bloqueo			Desbloqueo		Par			
	d	D	D1	H	H1	H2	H3	NV	Tv (Nm)	Tornillos	NV	Tornillos	Mt (Nm)	Pa (N/mm ²)	Ta (KN)	Pm (N/mm ²)
KLDB019	19	47	53	45	39	26	31	M6	17	4	M6	2	294	228	19,8	96
KLDB020	20	47	53	45	39	26	31	M6	17	4	M6	2	313	226	23,4	96
KLDB022	22	47	53	45	39	26	31	M6	17	4	M6	2	362	206	23,4	97
KLDB024	24	50	56	45	39	26	31	M6	17	6	M6	3	421	206	35,1	100
KLDB025	25	50	56	45	39	26	31	M6	17	6	M6	3	470	221	35,1	110
KLDB028	28	55	61	45	39	26	31	M6	17	6	M6	3	578	202	35,1	105
KLDB030	30	55	61	45	39	26	31	M6	17	6	M6	3	637	221	35,1	118
KLDB032	32	60	66	45	39	26	31	M6	17	8	M6	4	784	197	46,8	114
KLDB035	35	60	66	45	39	26	31	M6	17	8	M6	4	843	202	46,8	118
KLDB038	38	65	71	45	39	26	31	M6	17	8	M6	4	1010	197	46,8	121
KLDB040	40	65	71	45	39	26	31	M6	17	8	M6	4	1108	234	46,8	143
KLDB042	42	75	81	55	47	30	36	M8	41	6	M8	3	1892	216	46,8	135
KLDB045	45	75	81	55	47	30	36	M8	41	6	M8	3	1912	216	64,4	135
KLDB048	48	80	86	55	47	30	36	M8	41	6	M8	3	2137	221	73,6	142
KLDB050	50	80	86	55	47	30	36	M8	41	6	M8	3	2167	221	86	143
KLDB055	55	85	91	55	47	30	36	M8	41	8	M8	4	2677	221	86	143
KLDB060	60	90	96	55	47	30	36	M8	41	8	M8	4	2853	197	86	131
KLDB065	65	95	101	55	47	30	36	M8	41	8	M8	4	3500	206	86	142
KLDB070	70	110	116	67	57	40	46	M10	83	8	M10	4	5717	221	135	142
KLDB075	75	115	121	72	62	40	46	M10	83	8	M10	4	6207	216	135	148
KLDB080	80	120	126	72	62	40	46	M10	83	8	M10	4	6707	198	135	139
KLDB085	85	125	131	72	62	40	46	M10	83	10	M10	4	8002	216	169	157
KLDB090	90	130	136	72	62	40	46	M10	83	10	M10	4	8502	197	169	143
KLDB095	95	135	141	72	62	40	46	M10	83	10	M10	4	10002	187	169	138
KLDB100	100	145	151	89	77	46	52	M12	145	8	M12	4	13336	197	198	148
KLDB110	110	155	161	89	77	46	52	M12	145	8	M12	4	14582	197	198	178
KLDB120	120	165	171	89	77	46	52	M12	145	10	M12	4	19083	216	248	158
KLDB130	130	180	186	89	77	46	52	M12	145	12	M12	4	20417	198	297	143
KLDB140	140	190	196	90	84	51	59	M14	230	8	M14	4	24920	188	342	138
KLDB150	150	200	206	90	84	51	59	M14	230	10	M14	5	30130	198	342	149

2. Piñones, Discos, Tapers y casquillos de fijación



C&S 11 / SERIE KL EE

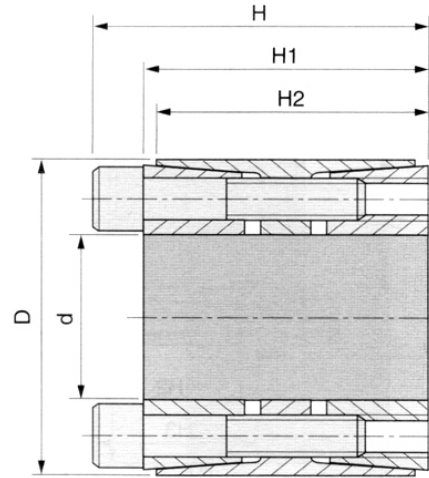
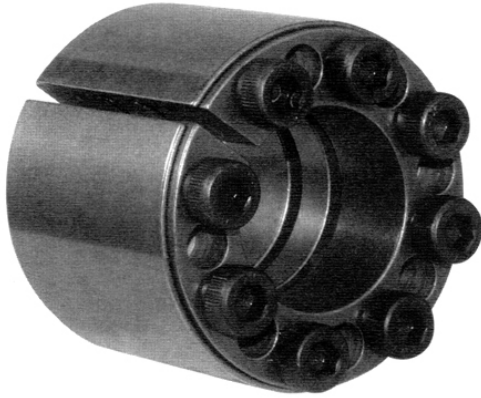

Dimensiones

Nuestro código	Dimensiones						Fuerza de bloqueo			Desbloqueo		Par			
	d	D	D1	H	H1	H2	NV	Tv (Nm)	Tornillos			Mt (Nm)	Pa (N/mm ²)	Ta (KN)	Pm (N/mm ²)
KLEE025	25	55		46	40	32	M6	17,5	6	M6	3	750	250	70	130
KLEE028	28	55		46	40	32	M6	17,5	6	M6	3	830	220	70	120
KLEE030	30	55		46	40	32	M6	17,5	6	M6	3	890	210	70	120
KLEE035	35	60		60	54	44	M6	17,5	7	M6	3	1220	150	80	90
KLEE038	38	55		62	54	44	M8	42	7	M8	3	2270	240	130	120
KLEE040	40	55		62	54	44	M8	42	7	M8	3	2390	230	130	140
KLEE042	42	75		62	54	44	M8	42	7	M8	3	2510	220	130	120
KLEE045	45	75		62	54	44	M8	42	7	M8	3	2690	200	130	120
KLEE048	48	80		62	54	44	M8	42	8	M8	3	3270	220	150	130
KLEE050	50	80		72	64	56	M8	42	8	M8	3	3410	170	150	110
KLEE055	55	85		72	64	56	M8	42	9	M8	3	4220	170	170	110
KLEE060	60	90		72	64	56	M8	42	10	M8	4	5110	170	180	120
KLEE065	65	95		72	64	56	M8	42	10	M8	4	5540	160	190	110
KLEE070	70	110		88	78	70	M10	85	10	M10	4	10150	200	310	130
KLEE075	75	115		88	78	70	M10	85	10	M10	4	10870	190	320	120
KLEE080	80	120		88	78	70	M10	85	12	M10	4	12760	190	340	130
KLEE085	85	125		88	78	70	M10	85	12	M10	5	14790	200	380	140
KLEE090	90	130		88	78	70	M10	85	12	M10	5	15660	190	380	130
KLEE095	95	135		88	78	70	M10	85	12	M10	5	16530	180	380	130
KLEE100	100	145		112	100	90	M12	145	12	M12	4	23250	180	510	120
KLEE110	110	155		112	100	90	M12	145	12	M12	5	27900	170	530	130
KLEE120	120	165		112	100	90	M12	145	14	M12	5	35510	190	650	140
KLEE130	130	180		130	116	104	M14	235	12	M14	5	45130	180	770	130
KLEE140	140	190		130	116	104	M14	235	14	M14	7	56700	190	870	140
KLEE150	150	200		130	116	104	M14	235	16	M14	7	65090	190	940	140
KLEE160	160	210		130	116	104	M14	235	16	M14	7	74060	190	1000	150
KLEE170	170	225		164	148	134	M16	360	14	M16	7	95240	170	1220	130
KLEE180	180	235		164	148	134	M16	360	16	M16	7	108050	170	1290	130
KLEE190	190	250		164	148	134	M16	360	16	M16	7	121650	170	1360	130
KLEE200	200	260		164	148	134	M16	360	16	M16	7	128060	160	1350	130
KLEE220	220	285		164	148	134	M16	360	18	M16	8	158470	170	1580	130



2. Piñones, Discos, Tapers y casquillos de fijación

C&S 55 / SERIE KL FF

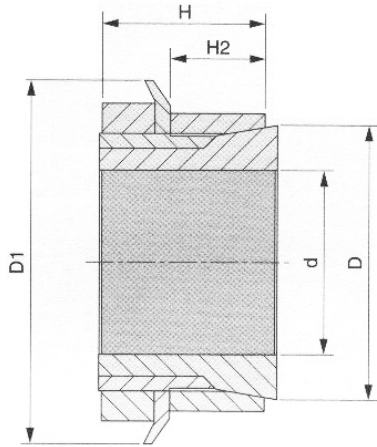

Dimensiones

Nuestro código	Dimensiones					Fuerza de bloqueo		Par			
	d	D	D1	H	H2	NV	Tv (Nm)	Mt (Nm)	Pa (N/mm ²)	Ta (kN)	Pm (N/mm ²)
KLFF015	15	25	32	31	23	M20x1	95	70	80		45
KLFF018	18	30	38	33	24	M25x1,5	160	100	75		45
KLFF019	19	30	38	33	24	M25x1,5	160	105	75		45
KLFF020	20	30	38	33	24	M25x1,5	160	112	70		45
KLFF024	24	35	45	38	29	M30x1,5	220	178	65		45
KLFF025	25	35	45	38	29	M30x1,5	220	185	60		45
KLFF028	28	40	52	44	34	M35x1,5	340	250	55		40
KLFF030	30	40	52	44	34	M35x1,5	340	270	50		40
KLFF035	35	45	58	45	34	M40x1,5	480	390	55		45
KLFF040	40	50	65	46	35	M45x1,5	680	520	55		45
KLFF045	45	55	70	47	35	M50x1,5	870	680	60		50
KLFF050	50	60	75	48	36	M55x2	970	880	60		50
KLFF055	55	65	80	48	36	M60x2	1100	1030	60		50
KLFF060	60	70	85	50	36	M65x2	1300	1360	65		55

2. Piñones, Discos, Tapers y casquillos de fijación



C&S 40 / SERIE KL GG

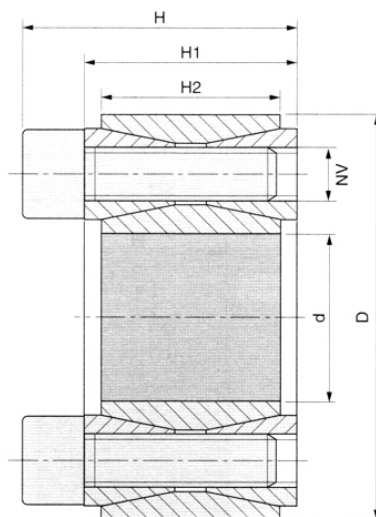
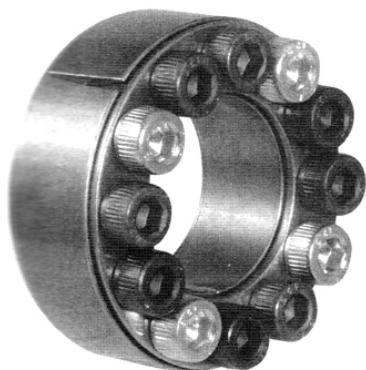

Dimensiones

Nuestro código	Dimensiones					Fuerza de bloqueo			Desbloqueo		Par			
	d	D	H	H1	H2	NV	Tv (Nm)	Tornillos	NV	Tornillos	Mt (Nm)	Pa (N/mm ²)	Ta (KN)	Pm (N/mm ²)
KLGG019	19	47	26	20	17	M6	16	8	M8	2	260	220	26,8	93
KLGG020	20	47	26	20	17	M6	16	8	M8	2	268	210	26,8	93
KLGG022	22	47	26	20	17	M6	16	8	M8	2	283	207	26,8	96
KLGG024	24	50	26	20	17	M6	16	9	M8	3	361	206	30,1	103
KLGG025	25	50	26	20	17	M6	16	9	M8	3	376	206	30,1	103
KLGG028	28	55	26	20	17	M6	16	10	M8	3	420	204	33,5	103
KLGG030	30	55	26	20	17	M6	16	10	M8	3	450	190	33,5	103
KLGG032	32	60	26	20	17	M6	16	12	M8	4	643	214	40,2	114
KLGG035	35	60	26	20	17	M6	16	12	M8	4	703	196	40,2	114
KLGG038	38	65	26	20	17	M6	16	14	M8	4	891	204	46,9	122
KLGG040	40	65	26	20	17	M6	16	14	M8	4	938	200	46,9	122
KLGG042	42	75	32	24	20	M8	38	12	M10	4	1537	228	73,2	125
KLGG045	45	75	32	24	20	M8	38	12	M10	4	1647	208	73,2	125
KLGG048	48	80	32	24	20	M8	38	12	M10	4	1756	190	73,2	110
KLGG050	50	80	32	24	20	M8	38	12	M10	4	1830	189	73,2	115
KLGG055	55	85	32	24	20	M8	38	14	M10	4	2348	200	85,4	130
KLGG060	60	90	32	24	20	M8	38	14	M10	4	2560	180	85,4	122
KLGG065	65	95	32	24	20	M8	38	16	M10	4	3170	191	97,6	130
KLGG070	70	110	38	28	24	M10	75	14	M12	4	4700	211	134,4	132
KLGG075	75	115	38	28	24	M10	75	14	M12	4	5000	194	134,4	128
KLGG080	80	120	38	28	24	M10	75	14	M12	4	5300	182	134,4	124
KLGG085	85	125	38	28	24	M10	75	16	M12	4	6500	196	153,6	133
KLGG090	90	130	38	28	24	M10	75	16	M12	4	6900	181	153,6	128
KLGG095	95	135	38	28	24	M10	75	18	M12	4	8200	196	172,8	139
KLGG100	100	145	45	33	26	M12	130	14	M14	4	9870	196	197,4	139
KLGG110	110	155	45	33	26	M12	130	14	M14	4	10800	181	187,4	128
KLGG120	120	165	45	33	26	M12	130	16	M14	4	13500	187	225,6	139
KLGG130	130	180	50	38	34	M12	130	20	M14	4	18300	168	282	119
KLGG140	140	190	50	38	34	M12	130	22	M14	4	21700	168	310,1	128
KLGG150	150	200	50	38	34	M12	130	24	M14	4	25300	170	338,4	128
KLGG160	160	210	50	38	34	M12	130	26	M14	4	29300	171	366,6	132
KLGG170	170	225	58	44	38	M14	207	22	M16	4	33000	162	389	123
KLGG180	180	235	58	44	38	M14	207	24	M16	4	38000	168	424	128
KLGG190	190	250	66	52	46	M14	207	28	M16	4	47000	154	495	114
KLGG200	200	260	66	52	46	M14	207	30	M16	4	53000	157	531	118



2. Piñones, Discos, Tapers y casquillos de fijación

C&S 45 / SERIE KL HH

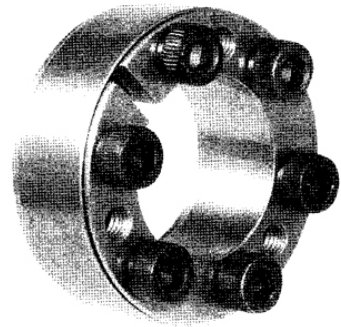
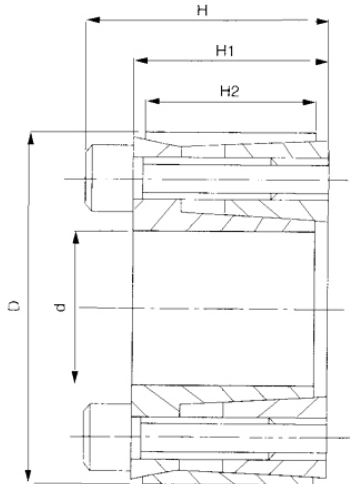

Dimensiones

Nuestro código	Dimensiones						Fuerza de bloqueo			Desbloqueo		Par			
	d	D	D1	H	H1	H2	NV	Tv (Nm)	Tornillos	Desbloqueo		Mt (Nm)	Pa (N/mm ²)	Ta (KN)	Pm (N/mm ²)
										NV	N° Viti				
KLHH 019	19	41		24,5	18,5	12	M6	17,5	6	M8	2	210	260		120
KLHH 020	20	42		24,5	18,5	12	M6	17,5	6	M8	2	240	250		120
KLHH 024	24	46		24,5	18,5	12	M6	17,5	6	M8	2	290	250		120
KLHH 025	25	47		24,5	18,5	12	M6	17,5	8	M8	2	330	230		120
KLHH 028	28	50		24,5	18,5	12	M6	17,5	8	M8	2	370	220		120
KLHH 030	30	52		24,5	18,5	12	M6	17,5	8	M8	2	430	210		120
KLHH 035	35	57		28	22	15	M6	17,5	12	M8	3	610	170		100
KLHH 038	38	60		28	22	15	M6	17,5	12	M8	3	380	170		100
KLHH 040	40	62		28	22	15	M6	17,5	12	M8	3	780	170		100
KLHH 042	42	70		36	28	18	M8	42	12	M10	3	1480	190		110
KLHH 045	45	73		36	28	18	M8	42	12	M10	3	1500	210		130
KLHH 048	48	76		36	28	18	M8	42	12	M10	3	1550	210		130
KLHH 050	50	78		36	28	18	M8	42	12	M10	3	1650	190		120
KLHH 055	55	83		36	28	18	M8	42	16	M10	4	2000	190		120
KLHH 060	60	88		36	28	18	M8	42	16	M10	4	2350	190		120
KLHH 070	70	105		45	35	22	M8	42	16	M10	4	3900	180		120
KLHH 080	80	115		45	35	22	M10	85	16	M12	3	4800	170		120

2. Piñones, Discos, Tapers y casquillos de fijación



C&S 95 / SERIE KL MM

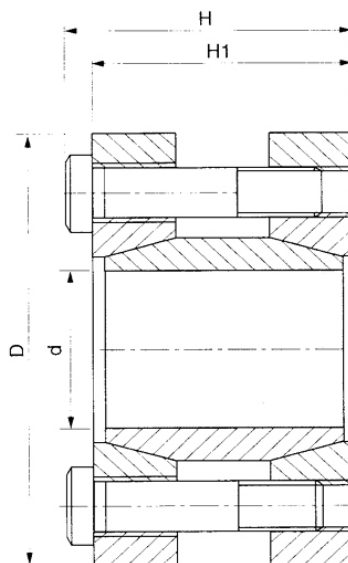
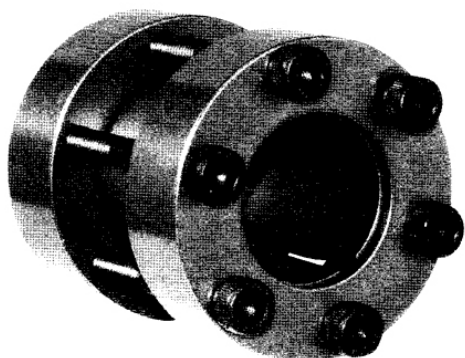

Dimensiones

Nuestro código	Dimensiones				Fuerza de bloqueo			Par			
	d	D	H ₁	H	NV	Tv (Nm)	Tornillos	Mt (Nm)	Pa (N/mm ²)	Ta (KN)	Pm (N/mm ²)
KLMM017	17	50	50	56	M6	17,5	4	200	110		
KLMM018	18	50	50	56	M6	17,5	4	220	110		
KLMM019	19	50	50	56	M6	17,5	4	230	110		
KLMM020	20	50	50	56	M6	17,5	4	240	105		
KLMM024	24	55	60	66	M6	17,5	4	290	120		
KLMM025	25	55	60	66	M6	17,5	6	450	110		
KLMM028	28	60	60	66	M6	17,5	6	510	110		
KLMM030	30	60	60	66	M6	17,5	6	550	105		
KLMM032	32	63	60	66	M6	17,5	6	580	90		
KLMM035	35	75	75	83	M8	42	4	790	105		
KLMM038	38	75	75	83	M8	42	4	850	100		
KLMM040	40	75	75	83	M8	42	4	900	95		
KLMM042	42	78	75	83	M8	42	4	950	90		
KLMM045	45	85	85	93	M8	42	6	1520	110		
KLMM048	48	90	85	93	M8	42	6	1620	100		
KLMM050	50	90	85	93	M8	42	6	1690	95		
KLMM055	55	94	85	93	M8	42	8	2470	110		
KLMM060	60	100	85	93	M8	42	8	2710	95		
KLMM065	65	105	85	93	M8	42	8	2930	90		
KLMM070	70	115	100	110	M10	85	6	3770	90		



2. Piñones, Discos, Tapers y casquillos de fijación

C&S 50 / SERIE KL NN

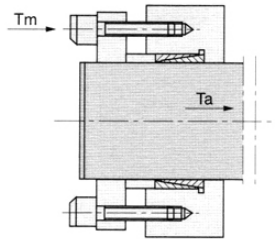
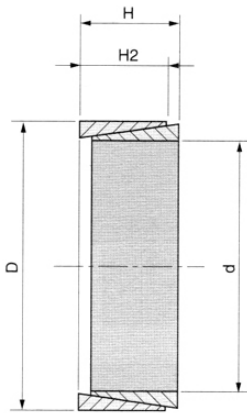

Dimensiones

Nuestro código	Dimensiones					Fuerza de bloqueo		Tornillos	Par				
	d	D	D1	H	H2	NV	Tv (Nm)		Ta (KN)	Mt (Nm)	Pa (N/mm ²)	Ta (KN)	Pm (N/mm ²)
KLNN008	8	11		4,5	3,7				0,97	4,3	2,9	98	73
KLNN010	10	13		4,5	3,7				1,37	12,1	6,9	98	75
KLNN012	12	15		4,5	3,7				1,64	12,4	9,8	98	78
KLNN014	14	18		6,3	5,3				2,74	20,4	19,2	98	76
KLNN015	15	19		6,3	5,3				2,94	23,5	22,1	98	77
KLNN016	16	20		6,3	5,3				3,14	23,9	25,1	98	78
KLNN018	18	22		6,3	5,3				3,53	24,8	31,8	98	80
KLNN019	19	24		6,3	5,3				3,72	29,1	35,3	98	77
KLNN020	20	25		6,3	5,3				3,92	29,5	39,2	98	78
KLNN022	22	26		6,3	5,3				4,31	28,3	47	98	83
KLNN024	24	28		6,3	5,3				4,7	29,4	56,8	98	84
KLNN025	25	30		6,3	5,3				4,9	31,8	60,8	98	81
KLNN028	28	32		6,3	5,3				5,49	31,9	76,4	98	86
KLNN030	30	35		6,3	5,3				5,88	34,8	88,2	98	84
KLNN032	32	36		6,3	5,3				6,27	35,9	100	98	87
KLNN035	35	40		7	6,0				7,74	44,8	136	98	86
KLNN038	38	44		7	6,0				8,43	48,8	160	98	84
KLNN040	40	45		8	6,6				9,75	57,6	195	98	87
KLNN042	42	48		8	6,6				10,3	61,4	216	98	86
KLNN045	45	52		10	8,6				14,3	90,3	321	98	85
KLNN048	48	55		10	8,6				15,3	92,7	367	98	85
KLNN050	50	57		10	8,6				15,9	94,7	397	98	86
KLNN055	55	62		10	8,6				17,4	99,7	480	98	87
KLNN060	60	68		12	10,4				23	130,9	692	98	86
KLNN065	65	73		12	10,4				25	134,9	813	98	87
KLNN070	70	79		14	12,2				31,6	172,4	1110	98	87
KLNN075	75	84		14	12,2				33,8	185,7	1260	98	87
KLNN080	80	91		17	15,0				44,1	247,1	1770	98	86
KLNN090	90	101		17	15,0				50	266,2	2240	98	87
KLNN100	100	114		21	18,7				69,6	370,8	3450	98	86
KLNN110	110	124		21	18,7				76,4	406,1	4170	98	87
KLNN120	120	134		21	18,7				83,3	432	4950	98	88
KLNN130	130	148		28	25,3				122	640,8	7840	98	86
KLNN140	140	158		28	25,3				131	676,5	9110	98	87
KLNN150	150	168		28	25,3				140	713	10500	98	87

2. Piñones, Discos, Tapers y casquillos de fijación



C&S 19 / SERIE KL PP

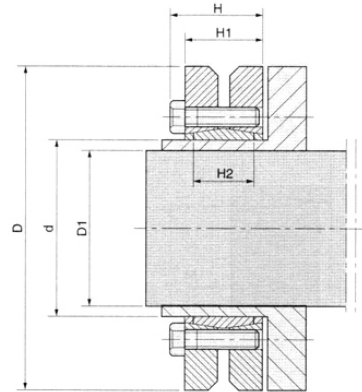
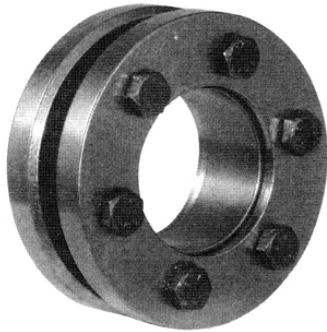

Dimensiones

Nuestro código	Dimensiones						Fuerza de bloqueo			Par		
	d	D	D1	H	H1	H2	NV	Tv (Nm)	Tornillos	Mt (Nm)	Pa (N/mm ²)	Ta (KN)
KLPP024	24	50	20	23	19,5	14	M5	4,9	6	170	286	15,0
			21							210		18,5
			24							250		21,0
KLPP030	30	60	25	25	21,5	16	M5	4,9	7	300	233	15,7
			26							340		23,7
			28							380		26,7
KLPP036	36	72	30	27,5	23,5	18	M6	11,8	5	440	307	27,0
			31							570		38,0
			32							630		43,0
KLPP044	44	80	35	29,5	25,5	20	M6	11,8	7	620	317	44,0
			36							780		49,0
			38							860		54,0
KLPP050	50	90	40	31,5	27,5	22	M6	11,8	8	940	289	48,8
			42							1160		58,8
			42							1380		69,0
KLPP055	55	100	45	34,5	30,5	23	M6	11,8	8	1160	252	48,0
			48							1520		61,7
			48							1880		77,0
KLPP062	62	110	50	34,5	30,5	23	M6	11,8	10	1850	279	69,0
			52							2200		80,9
			50							2400		90,0
KLPP068	68	115	55	34,5	30,5	23	M6	11,8	10	2000	255	71,2
			60							2500		80,9
			55							3150		95,7
KLPP075	75	138	60	37,8	32,5	25	M8	29,4	7	2500	273	94,4
			65							3200		111,0
			60							3950		126,0
KLPP080	80	145	65	37,8	32,5	25	M8	29,4	7	3200	256	99,3
			70							3900		115,0
			65							4600		130,0
KLPP090	90	155	70	44,3	39	30	M8	29,4	10	4750	271	141,0
			75							6000		160,0
			70							7250		178,0
KLPP100	100	170	75	49,3	44	34	M8	29,4	12	6900	258	163,0
			80							7500		182,0
			75							9000		202,0
KLPP110	110	185	80	56,4	50	39	M10	57,8	9	7200	244	185,0
			85							9000		207,0
			85							10800		221,0
KLPP125	125	215	90	60,4	54	42	M10	57,8	12	11000	266	240,0
			95							13000		262,0
			95							15000		285,0
KLPP140	140	230	100	68	60,5	46	M12	98	10	15100	264	308,0
			105							17600		331,0
			105							20100		357,0
KLPP155	155	263	110	72	64,5	50	M12	98	12	22000	263	366,0
			115							25000		392,0
			115							28000		417,0
KLPP165	165	290	120	81	71	56	M16	245	8	31000	277	513,0
			125							25000		544,0
										39000		564,0

KLGG	RCK 40	A	210	2000	112	RFN 7012	4000	1120	TLK 200	100	1	400	2005	3020	30	1	2001	1000
KLCC	RCK 80	B	55	1000	110	TI 9011	8000	1100	BK11/TLK110	250	3	800	5061		10	2		3000
KLNN	RCK 50	C	31	3000	106	RFN 8006	5000	1060	TLK300	160	2	500	3003		80	3	3001	2000
KLDA	RCK 70	D	54/N	4000	131	TI 9013.A	7000A	1300.1	TLK13A/130	200	5A	700	6901		20	4		5000A
KLAA	RCK 13	DS	913	4100	133	RFN 7013.0	1003	1710	TLK103/132	203	6	130	1062	3003		5	2002	5006
KLDB	RCK 71	E	54/S	4500	132	TI 9013.B	7000B	1300.2	TLK130/131	201	5B	700.1	6902		20-B	6		5000B
KLBB	RCK 15	EP	914/SP	4900			1506	2400	TLK134/156	256	8F	156	3061			16		
		ER	54 X															
KLAB	RCK 16	ES	914	4600	136	RFN 7013.1	1006	1720	TLK106/133	206	7	160	1061	3006		7	2002.3	5007
KLBE	RCK 11	F	910	9500	145	RFN 7015.0	1012**	1800	TLK400	400	4	112	4061	3012	70	8		700
		FS				RFN 7015.1	1015		TLK401	400.1			1008	3015				
		G	911	9000	141			1400*							40	9		4000
		H	25/C	5000	150		5500SP*	1500C	TLK250***	125	9	550C	3505		50	10		6050
KLFF	RCK 55	I	25/L	5500	151		5500S*	1500	TLK250L	125L	13S	550L	3705		60	11		6000
KLHH	RCK 45	L	720	6000	100	TI 9009	4500	1000	BK9/TLK109	90	12S	450	4005		100	12		1010
KLMM	RCK 95	M	912	7000	160	RFN 7020	9500	1600	TLK500	700	10S	950	1004		90	13		9000
KLPP	RCK 19	SD	915	8000	271	RFN 4071	1029.1	2200	TLK603	603	11S	129	2008			14	5000.3	